

REVISIONS			
REV.	DESCRIPTION	DATE	APPROVED

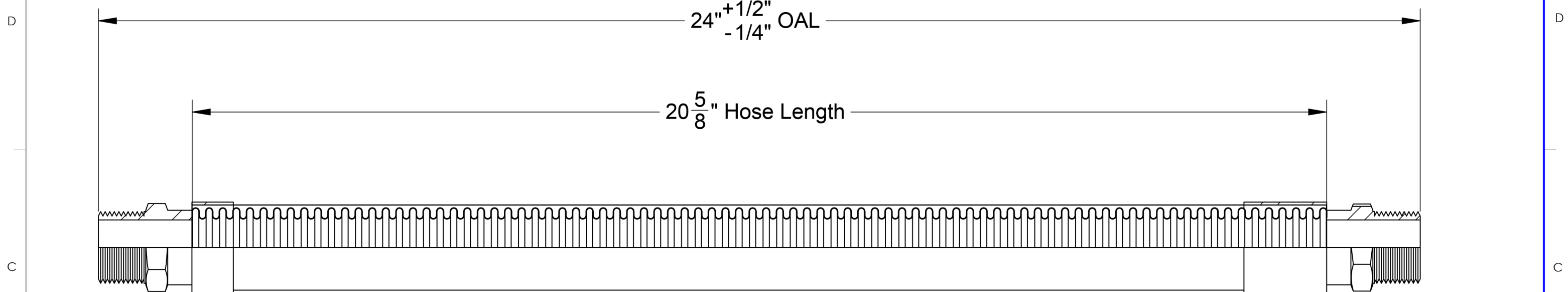

ITEM #	QTY.	PART NUMBER	DESCRIPTION	MATERIAL	WEIGHT
1	1	HOSE	300 Series Stainless HYDROFORMED Corrugated Hose	Stainless Steel	0.50
2	1	BRAID	300 Series Stainless Steel	Stainless Steel	0.06
3	1	BRAID COLLAR	0.05" Thick	Stainless Steel	0.05
4	1	BRAID COLLAR 2	0.05" Thick	Stainless Steel	0.11
5	2	1" MALE	1" Male, 1"x11-1/2" Thread, 1.38" Hex	Stainless Steel	0.27

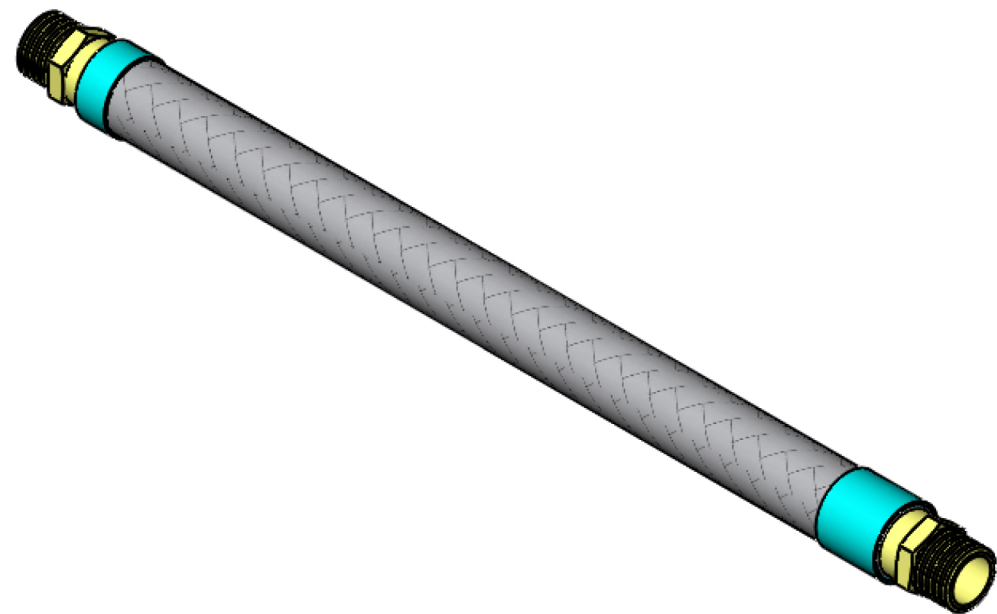

**HOSE MASTER Inc.**  
 1233 East 222nd Street • Cleveland, Ohio 44117  
 (800) 221-2319 • Fax: (216) 481-7557 • www.hosemaster.com  
 Locations: **Cleveland • Houston**

Registered to:  
ISO 9001 : 2000

**NAHAD**  
Listed Manufacturer

Projection:	Customer: Hose Master Inc.	Prepared By: kannk
	Reference: Fire-Shield - 1" Male x 1" Male x 24" OAL	CALC. WEIGHT: 1 lbs. Date: 9/24/2009
Description:	<b>1" ID x 24" OAL 300 Series Stainless HYDROFORMED Corrugated Hose covered by 300 Series Stainless Braid. UL Approved 1" Male Connectors</b>	
Drawing #:	<b>FSMM0100x24</b>	Rev.: - SHEET 1 OF 1

